

F510/C

Metal Shell Fingerprint Access Control

Vandal-proof

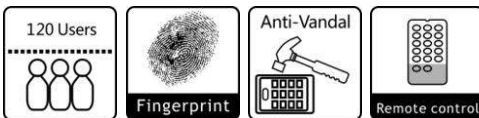

About

F510/C is the new member of F Series Standalone Fingerprint access control, as traditional it is in metal shell, anti-vandal, supports fingerprint, besides, F510C support RFID card (125KHZ EM card) and wiegand interface. The high security and more powerful feature make it an ideal choice for door access.

User capacity 2160, including 160 fingerprint users and 2000 RFID card users. With the flexible user capacity, it is suitable to be installed from small house such as personal rooms, shops, office to public place such as large factories, companies.

By Remote control or Master card for programming, it is so user friendly that anyone can use it.

Key Features

- ✓ Metal shell, anti-vandal, Fireproof, Shockproof.
- ✓ F510: 120 fingerprints, F510C: 160 fingerprints & 2000 Cards
- ✓ Remote infrared programmer
- ✓ Lock release relay, NO and NC, 12 Volt DC System
- ✓ F510C Wiegand26.
- ✓ Programmable lock release time
- ✓ Sleep mode to save energy
- ✓ Built in PIR to wake up the device
- ✓ Working temperature: -20-55
- ✓ Two year warranty;
- ✓ One second activation time, after placing finger on reader
- ✓ Size: 110mm*70m*30mm



Rain Shield

Technical Specification

Model NO.	F510
Metal Shell Fingerprint Access Control	
Supply Voltage	12VDC±10%
Sleeping Current	<20mA
Stay Current	<90mA
Temperature	-15°C60°C
Humidity	20%RH-95%RH
Memory capacity	2160
Fingerprint capacity	160
Card capacity	2000
Card type	125KHZ ID card
Card reading distance	50 ± 30 mm
Lock output load capacity	20A
Alarm output load capacity	20A
Resolution	450 DPI
Fingerprint input time	<1S
Identification time	<1S
FAR	<0.001%
FRR	<0.1%
Dimensions	110L*70W*30H(mm)
N/W	500g
G/W	800g

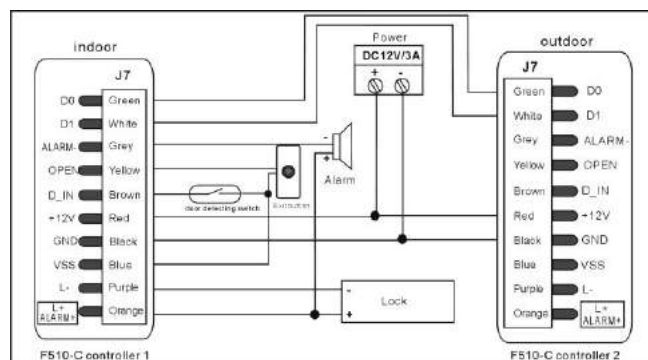
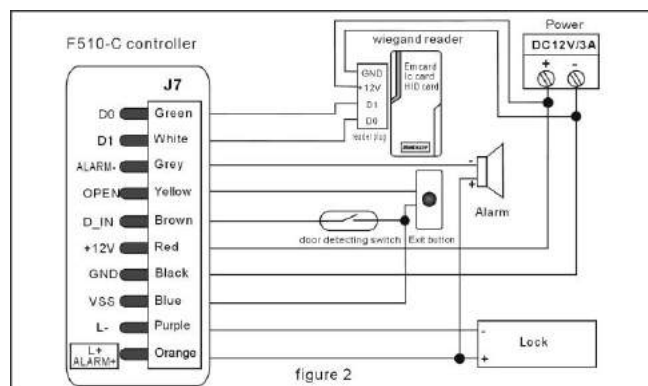

F510C (same plus)

- 160 Finger, 2000 Proximity Card
- Wiegand 26, (Connect to C520/NT)



© 2010 SOMAX All rights reserved.

All rights of this object belong to SOMAX. Reproduced or transmitted in any form, or by any means without the prior written permission of SOMAX is prohibited. SOMAX reserves the rights to modify its products, including their specifications and any other information stated herein without notice. The official printout of any information shall prevail should there be any discrepancy between the information contained herein and the information contained in that printout. "SOMAX" is a trademark owned by SOMAX. Integrated Other trademarks used herein for description purpose only belong to each of their companies.

